

Indice	Index	Pag. Page
Caratteristiche tecniche	<i>Technical features</i>	L2
Designazione	<i>Designation</i>	L2
Versioni	<i>Versions</i>	L2
Simbologia	<i>Symbols</i>	L2
Lubrificazione	<i>Lubrication</i>	L3
Posizione di montaggio	<i>Mounting position</i>	L3
Dati tecnici	<i>Technical data</i>	L4
Dimensioni	<i>Dimensions</i>	L8
Accessori	<i>Accessories</i>	L10
Optional	<i>Options</i>	L10



Questa sezione annulla e sostituisce ogni precedente edizione o revisione. Qualora questa sezione non Vi sia giunta in distribuzione controllata, l'aggiornamento dei dati ivi contenuto non è assicurato. **In tal caso la versione più aggiornata è disponibile sul nostro sito internet www.transtecno.com**

*This section replaces any previous edition and revision. If you obtained this catalogue other than through controlled distribution channels, the most up to date content is not guaranteed. **In this case the latest version is available on our web site www.transtecno.com***





Caratteristiche tecniche

Technical features

I motovariariduttori della serie CMV hanno le seguenti caratteristiche principali:

- Precisione nella regolazione della velocità, contenuta in $\pm 0.5/1\%$.
- Campo di regolazione continuo 1:5.
- Le grandezze CM040, 050, 063, 075, 090 e 110 sono costruite con carcassa in Alluminio, la grandezza 130 ha la carcassa in ghisa.
- Le grandezze VAM18, 037 e 075 sono costruite con carcassa in Alluminio, le altre grandezze in ghisa

CMV mechanical variators and wormgearboxes main features:

- Precision in speed regulation: $\pm 0.5/1\%$
- Speed range 1:5
- Die-cast aluminum housing on CM040, 050, 063, 075, 090 and 110. Cast iron housing on CM130.
- Die-cast aluminum housing on VAM018, 037 and 075. Cast iron housing on the other sizes.

Designazione

Designation

MOTOVARIARIDUTTORE / MECHANICAL VARIATOR AND GEARBOX								
CMV	040/037	FD	20	SZDX	BR SX	90	B3/1	VS
Tipo Type	Grandezza Size	Versione Version	Rapporto Ratio	Albero di uscita Output shaft	Braccio di reazione Torque arm	Angolo Angle	Pos. di montaggio Mounting position	Opzioni Options
CMV	040/018 — 130/40	U FD FS FBD FBS FLD FLS	vedi tabelle see tables	SZDX SZSX DZ	BRDX BR SX	0° 90° 180° 270°	Vedi pag. L3 See page L3	VS

MOTORE / MOTOR				
0.37kW	4p	3ph	50Hz	T1
Potenza Power	Poli Poles	Fasi Phases	Frequenza Frequency	Pos. morsetteria Terminal box pos.
Vedi tabelle See tables	2p 4p	1ph 3ph	50Hz 60Hz	Vedi pag. L3 See page L3

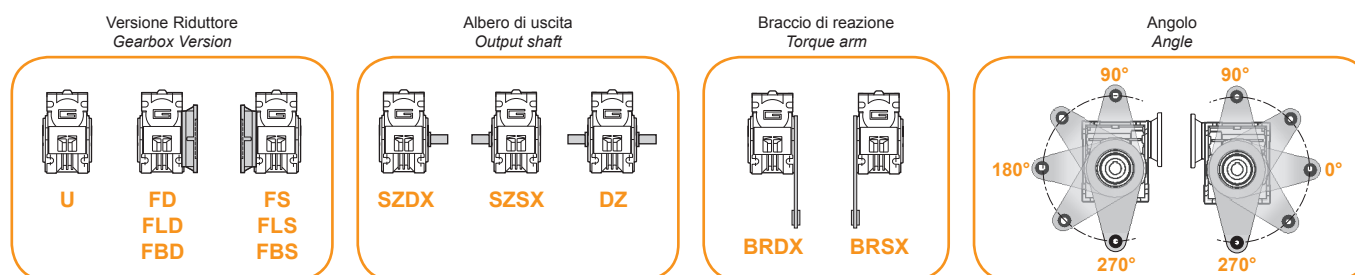

Simbologia

Symbols

n_1	[min^{-1}]	Velocità in ingresso / Input speed
n_2	[min^{-1}]	Velocità in uscita / Output speed
i		Rapporto di riduzione / Ratio
P_1	[kW]	Potenza in entrata / Input power

M_2	[Nm]	Coppia in uscita in funzione di P_1 / Output torque referred to P_1
sf		Fattore di servizio / Service factor
R_2	[N]	Carico radiale ammissibile in uscita / Permitted output radial load
A_2	[N]	Carico assiale ammissibile in uscita / Permitted output axial load



Lubrificazione

Lubrication

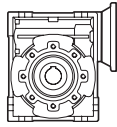

CM

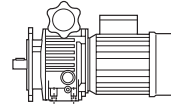

VAM

	Quantità di olio (litri) / Oil quantity (liters)					
	B3	B8	B6	B7	V5	V6
CM040	0.07					
CM050	0.1					
CM063	0.25					
CM075	0.3					
CM090	0.85					
CM110	1.5					
CM130	4.5	3.3	3.5	3.5	4.5	3.3

Lubrificati a vita
Life lubricated

	Quantità di olio (litri) / Oil quantity (liters)					
	VAM					
	018	037	075	15	22	40
B3 - B6 - B7 - B8	0.15	0.2	0.35	0.8	1.2	1.2
V5 - V6	0.2	0.3	0.45	1.0	1.2	1.2

Posizioni di montaggio

Mounting positions

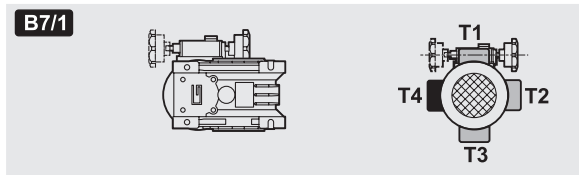
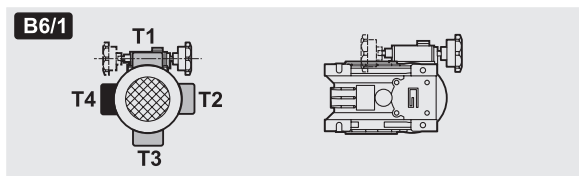
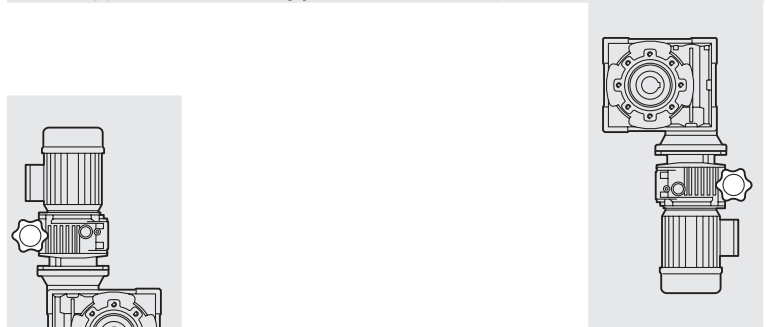
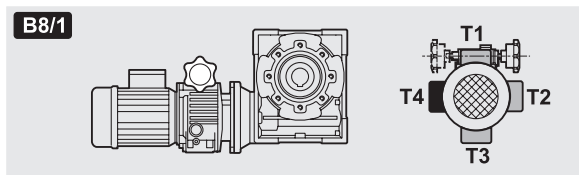
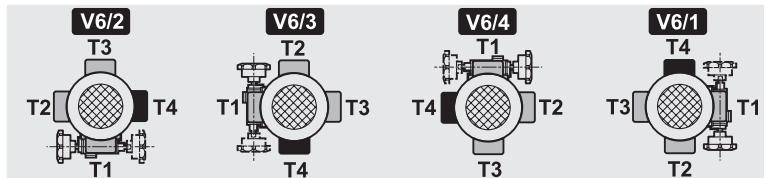
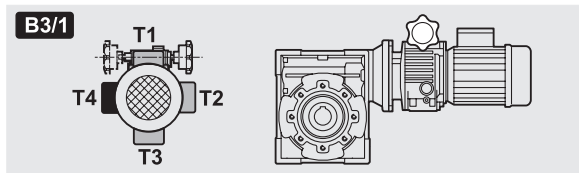



Carichi radiali

Radial loads

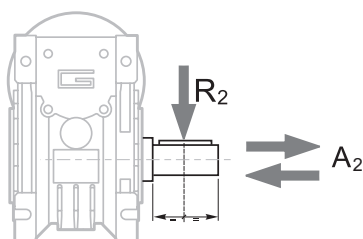

$$A_2 = R_2 \times 0.2$$

n ₂ [min ⁻¹]	R ₂ [N]						
	CM040	CM050	CM063	CM075	CM090	CM110	CM130
187	1264	1770	2445	2824	3161	5058	5732
140	1392	1949	2692	3110	3481	5570	6313
93	1596	2234	3085	3564	3990	6384	7235
70	1754	2456	3392	3918	4386	7018	7953
56	1890	2646	3654	4221	4725	7560	8567
47	2004	2805	3874	4475	5009	8014	9083
35	2210	3095	4273	4937	5526	8842	10021
28	2381	3334	4603	5318	5953	9524	10794
23	2542	3559	4915	5678	6356	10170	11526
18	2759	3862	5334	6162	6897	11036	12507
14	3000	4200	5800	6700	7500	12000	13600

Quando il carico radiale risultante non è applicato sulla mezza-
 ria dell'albero occorre calcolare quello effettivo con la seguente
 formula:

When the resulting radial load is not applied on the centre
 line of the shaft it is necessary to calculate the effective load with the
 following formula:

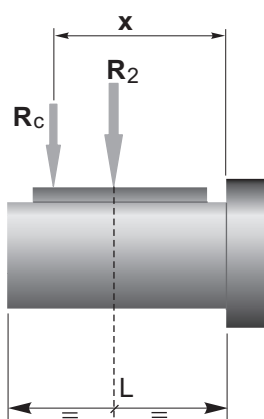

	CM						
	040	050	063	075	090	110	130
a	84	101	120	131	182	176	188
b	64	76	95	101	122	136	148
R _{2MAX}	3000	4200	5800	6700	7500	12000	13600

$$R_c = \frac{R_2 \cdot a}{(b + x)} \leq R_{2MAX}$$

$$R \leq R_c$$

a, b = valori riportati nella tabella
 a, b = values given in the table



Dati tecnici

Technical data

P ₁ [kW]	velocità massima max speed			velocità minima min speed			i	
	n ₂ [min ⁻¹]	M ₂ [Nm]	sf	n ₂ [min ⁻¹]	M ₂ [Nm]	sf		

P ₁ [kW]	velocità massima max speed			velocità minima min speed			i	
	n ₂ [min ⁻¹]	M ₂ [Nm]	sf	n ₂ [min ⁻¹]	M ₂ [Nm]	sf		

0.22

63C4 n ₁ =1400 [min ⁻¹]	176	8	5.6	34.0	15	5.2	5	CMV 040/018
	117	12	4.3	22.7	22	3.8	7.5	
	88.0	16	3.3	17.0	29	2.9	10	
	58.7	22	2.5	11.3	39	2.2	15	
	44.0	28	1.6	8.5	51	1.5	20	
	35.2	33	1.3	6.8	61	1.1	25	
	29.3	38	1.5	5.7	65	1.4	30	
	22.0	46	1.1	4.3	79	0.9	40	
	17.6	54	0.8	3.4	89	0.8	50	
	22.0	47	1.8	4.3	81	1.7	40	
17.6	56	1.4	3.4	91	1.4	50		
14.7	63	1.2	2.8	100	1.1	60		
11.0	73	0.9	2.1	116	0.8	80		
8.8	82	0.8	1.7	129	0.7	100	CMV 063/018	
14.7	66	2.1	2.8	105	2.0	60		
11.0	79	1.6	2.1	122	1.5	80		
8.8	89	1.4	1.7	133	1.2	100		

0.37

71B4 n ₁ =1400 [min ⁻¹]	66.7	36	2.7	13.3	65	2.5	15	CMV 050/037	
	50.0	45	1.8	10.0	82	1.7	20		
	40.0	54	1.4	8.0	96	1.3	25		
	33.3	61	1.6	6.7	104	1.6	30		
	25.0	74	1.1	5.0	127	1.1	40		
	20.0	89	0.9	4.0	144	0.9	50		
	16.7	99	0.8	3.3	158	0.7	60		
	25.0	78	2.1	5.0	130	2.0	40		CMV 063/037
	20.0	92	1.6	4.0	150	1.5	50		
	16.7	104	1.4	3.3	166	1.3	60		
12.5	125	1.0	2.5	192	1.0	80			
10.0	141	0.9	2.0	210	0.8	100	CMV 075/037		
16.7	110	2.1	3.3	176	2.0	60			
12.5	132	1.6	2.5	206	1.5	80			
10.0	150	1.3	2.0	228	1.2	100			
10.0	165	1.9	2.0	252	1.7	100	CMV 090/037		

0.37

63C2 n ₁ =2800 [min ⁻¹]	352	7	5.5	68.0	16	3.8	5	CMV 040/018	
	235	11	4.0	45.3	23	2.8	7.5		
	176	14	3.2	34.0	30	2.2	10		
	117	21	2.2	22.7	42	1.6	15		
	88.0	27	1.5	17.0	53	1.1	20		
	70.4	31	1.2	13.6	63	0.8	25		
	58.7	36	1.3	11.3	72	1.0	30		
	44.0	44	1.0	8.5	88	0.7	40		
	88.0	27	2.7	17.0	54	1.9	20		CMV 050/018
	70.4	32	2.2	13.6	64	1.4	25		
58.7	37	2.4	11.3	74	1.7	30			
44.0	46	1.7	8.5	90	1.2	40			
35.2	54	1.3	6.8	105	1.0	50	CMV 063/018		
29.3	61	1.1	5.7	116	0.8	60			
35.2	56	2.4	6.8	108	1.8	50			
29.3	64	2.0	5.7	121	1.5	60			
22.0	78	1.5	4.3	143	1.1	80			
17.6	88	1.3	3.4	160	0.9	100			

0.55

71B2 n ₁ =2800 [min ⁻¹]	400	10	3.6	80.0	25	2.4	5	CMV 040/037	
	267	14	2.6	53.3	37	1.8	7.5		
	200	19	2.1	40.0	47	1.4	10		
	133	27	1.5	26.7	66	1.0	15		
	100	35	1.0	20.0	84	0.7	20		
	267	15	4.7	53.3	37	3.2	7.5		CMV 050/037
	200	19	3.8	40.0	48	2.5	10		
	133	28	2.6	26.7	68	1.7	15		
	100	36	1.8	20.0	85	1.2	20		
	80.0	43	1.4	16.0	101	0.9	25		CMV 063/037
66.7	49	1.6	13.3	117	1.1	30			
50.0	62	1.1	10.0	142	0.8	40			
100	36	3.3	20.0	88	2.1	20			
80.0	44	2.6	16.0	105	1.6	25	CMV 075/037		
66.7	51	2.9	13.3	115	2.0	30			
50.0	64	2.0	10.0	144	1.4	40			
40.0	76	1.6	8.0	171	1.1	50			
33.3	87	1.3	6.7	191	0.9	60	CMV 090/037		
25.0	107	1.0	5.0	226	0.7	80			
50.0	66	3.2	10.0	156	2.2	40			
40.0	78	2.4	8.0	183	1.7	50			
33.3	91	2.0	6.7	205	1.4	60	CMV 075/037		
25.0	113	1.5	5.0	240	1.0	80			
20.0	130	1.2	4.0	270	0.8	100			
33.3	95	3.1	6.7	212	2.2	60		CMV 090/037	
25.0	118	2.3	5.0	254	1.6	80			
20.0	139	1.8	4.0	288	1.3	100			





Dati tecnici

Technical data

P ₁ [kW]	velocità massima max speed			velocità minima min speed			i	
	n ₂ [min ⁻¹]	M ₂ [Nm]	sf	n ₂ [min ⁻¹]	M ₂ [Nm]	sf		

P ₁ [kW]	velocità massima max speed			velocità minima min speed			i	
	n ₂ [min ⁻¹]	M ₂ [Nm]	sf	n ₂ [min ⁻¹]	M ₂ [Nm]	sf		

0.75

80B4 n ₁ =1400 [min ⁻¹]	133	38	2.4	26.7	71	2.2	7.5	CMV 050/075	
	100	50	1.9	20.0	91	1.7	10		
	66.7	71	1.3	13.3	130	1.2	15		
		50.0	90	0.9	10.0	163	0.8	20	CMV 063/075
		40.0	108	0.7	8.0	192	0.6	25	
		33.3	122	0.8	6.7	209	0.8	30	
		66.7	73	2.4	13.3	128	2.4	15	CMV 075/075
		50.0	94	1.6	10.0	161	1.6	20	
		40.0	113	1.2	8.0	189	1.2	25	
		33.3	126	1.5	6.7	216	1.4	30	CMV 090/075
		25.0	156	1.0	5.0	259	1.0	40	
		20.0	183	0.8	4.0	300	0.8	50	
	40.0	110	2.1	8.0	198	1.9	25	CMV 110/075	
	33.3	122	2.5	6.7	227	2.3	30		
	25.0	154	1.7	5.0	274	1.6	40		
	20.0	192	1.3	4.0	318	1.2	50	CMV 110/075	
	16.7	220	1.1	3.3	353	1.0	60		
	12.5	264	0.8	2.5	413	0.7	80		
	25.0	173	2.7	5.0	293	2.6	40	CMV 090/075	
	20.0	204	2.0	4.0	342	1.9	50		
	16.7	234	1.6	3.3	382	1.5	60		
	12.5	288	1.2	2.5	451	1.1	80	CMV 110/075	
	10.0	330	1.0	2.0	504	0.9	100		
	12.5	302	2.0	2.5	490	1.8	80		
	10.0	354	1.6	2.0	552	1.4	100		

1.1

90S4 n ₁ =1400 [min ⁻¹]	133	58	2.9	26.7	108	2.7	7.5	CMV 063/15	
	100	76	2.3	20.0	139	2.1	10		
	66.7	109	1.6	13.3	192	1.6	15		
		50.0	140	1.1	10.0	241	1.1	20	CMV 075/15
		40.0	169	0.8	8.0	284	0.8	25	
		33.3	189	1.0	6.7	324	1.0	30	
		50.0	144	1.8	10.0	248	1.7	20	CMV 090/15
		40.0	173	1.3	8.0	297	1.3	25	
		33.3	197	1.6	6.7	340	1.5	30	
		25.0	245	1.1	5.0	410	1.1	40	CMV 110/15
		25.0	259	1.8	5.0	439	1.7	40	
		20.0	306	1.4	4.0	513	1.2	50	
	16.7	351	1.1	3.3	572	1.0	60	CMV 110/15	
	16.7	367	1.9	3.3	616	1.6	60		
	12.5	454	1.3	2.5	734	1.2	80		
	10.0	531	1.0	2.0	828	0.9	100		

1.5

90L4 n ₁ =1400 [min ⁻¹]	133	77	2.2	26.7	144	2.0	7.5	CMV 063/15	
	100	101	1.7	20.0	185	1.6	10		
	66.7	146	1.2	13.3	256	1.2	15		
		50.0	187	0.8	10.0	322	0.8	20	CMV 075/15
		133	78	3.3	26.7	146	3.1	7.5	
		100	102	2.7	20.0	187	2.5	10	
		66.7	149	2.0	13.3	263	1.9	15	CMV 090/15
		50.0	192	1.3	10.0	331	1.3	20	
		40.0	231	1.0	8.0	396	1.0	25	
		33.3	263	1.2	6.7	454	1.1	30	CMV 110/15
		25.0	326	0.8	5.0	547	0.8	40	
		133	79	4.9	26.7	149	4.4	7.5	
	100	104	4.0	20.0	192	3.6	10	CMV 090/15	
	66.7	151	3.1	13.3	270	3.0	15		
	50.0	197	2.2	10.0	346	2.2	20		
	40.0	240	1.6	8.0	414	1.6	25	CMV 110/15	
	33.3	274	1.9	6.7	475	1.8	30		
	25.0	346	1.3	5.0	586	1.3	40		
	20.0	408	1.0	4.0	684	0.9	50	CMV 110/15	
	16.7	468	0.8	3.3	763	0.8	60		
	40.0	243	2.9	8.0	432	2.8	25		
	33.3	270	3.2	6.7	482	3.1	30	CMV 130/15	
	25.0	350	2.4	5.0	624	2.1	40		
	20.0	426	1.8	4.0	732	1.6	50		
	16.7	490	1.4	3.3	821	1.2	60	CMV 130/15	
	12.5	586	1.0	2.5	979	0.9	80		
	10.0	710	0.8	2.0	1104	0.7	100		
	20.0	438	2.4	4.0	732	2.0	50	CMV 130/15	
	16.7	504	1.9	3.3	821	1.7	60		
	12.5	614	1.4	2.5	979	1.2	80		
	10.0	708	1.1	2.0	1152	1.0	100		

1.1

80B2 n ₁ =2800 [min ⁻¹]	267	29	2.3	53.3	75	1.6	7.5	CMV 050/075	
	200	38	1.9	40.0	96	1.3	10		
	133	55	1.3	26.7	135	0.9	15		
		267	29	4.2	53.3	76	2.8	7.5	CMV 063/075
		200	38	3.4	40.0	98	2.2	10	
		133	56	2.4	26.7	139	1.6	15	
		100	72	1.6	20.0	175	1.1	20	CMV 075/075
		80.0	88	1.3	16.0	210	0.8	25	
		66.7	102	1.4	13.3	230	1.0	30	
		50.0	128	1.0	10.0	288	0.7	40	CMV 090/075
		100	74	2.7	20.0	180	1.7	20	
		80.0	90	2.0	16.0	216	1.3	25	
	66.7	104	2.3	13.3	252	1.5	30	CMV 110/075	
	50.0	132	1.6	10.0	312	1.1	40		
	40.0	158	1.2	8.0	366	0.8	50		
	33.3	182	1.0	6.7	410	0.7	60	CMV 090/075	
	66.7	107	3.8	13.3	252	2.5	30		
	50.0	137	2.6	10.0	317	1.8	40		
	40.0	165	1.9	8.0	366	1.4	50	CMV 110/075	
	33.3	190	1.5	6.7	425	1.1	60		
	25.0	236	1.1	5.0	509	0.8	80		
	20.0	277	0.9	4.0	576	0.6	100	CMV 110/075	
	40.0	169	3.4	8.0	390	2.3	50		
	33.3	198	2.6	6.7	446	1.8	60		
	25.0	246	1.9	5.0	547	1.3	80	CMV 110/075	
	20.0	290	1.5	4.0	624	1.0	100		



Dati tecnici

Technical data

P ₁ [kW]	velocità massima max speed			velocità minima min speed			i		P ₁ [kW]	velocità massima max speed			velocità minima min speed			i					
	n ₂ [min ⁻¹]	M ₂ [Nm]	sf	n ₂ [min ⁻¹]	M ₂ [Nm]	sf				n ₂ [min ⁻¹]	M ₂ [Nm]	sf	n ₂ [min ⁻¹]	M ₂ [Nm]	sf						
2.2									3												
90L2 n ₁ =2800 [min ⁻¹]	267	60	2.0	53.3	151	1.4	7.5	CMV 063/15	100LB4 n ₁ =1400 [min ⁻¹]	133	157	1.7	26.7	292	1.5	7.5	CMV 075/40				
	200	78	1.6	40.0	197	1.1	10			100	204	1.3	20.0	374	1.3	10					
	133	115	1.2	26.7	277	0.8	15			66.7	299	1.0	13.3	526	0.9	15					
	267	60	3.1	53.3	151	2.1	7.5	CMV 075/15		133	158	2.4	26.7	299	2.2	7.5	CMV 090/40				
		200	79	2.6	40.0	199	1.7				10	100	209	2.0	20.0	384		1.8	10		
		133	115	1.9	26.7	284	1.2				15	66.7	302	1.6	13.3	540		1.5	15		
		100	151	1.3	20.0	360	0.9				20	50.0	394	1.1	10.0	691		1.1	20		
		80.0	185	1.0	16.0	432	0.6				25	40.0	480	0.8	8.0	828		0.8	25		
		66.7	213	1.1	13.3	504	0.7				30	33.3	547	1.0	6.7	950		0.9	30		
	267	61	4.5	53.3	153	3.1	7.5	CMV 090/15		66.7	317	2.5	13.3	598	1.9	15	CMV 110/40				
		200	80	3.8	40.0	202	2.5				10	50.0	418	1.8	10.0	778		1.6	20		
		133	117	3.0	26.7	292	1.9				15	40.0	504	1.4	8.0	912		1.5	25		
100		153	2.2	20.0	374	1.4	20		33.3		598	1.5	6.7	1080	1.2	30					
80.0		189	1.6	16.0	450	1.0	25		25.0		787	1.1	5.0	1382	0.9	40					
66.7		219	1.8	13.3	504	1.3	30		20.0		936	0.8	4.0	1608	0.9	50					
50.0		281	1.3	10.0	634	0.9	40		CMV 110/15		16.7	1080	0.6	3.3	1872	0.7		60	CMV 130/40		
		40.0	338	0.9	8.0	732	0.7					50	40.0	486	2.2	8.0		876		1.7	25
		80.0	191	2.8	16.0	462	1.8					25	33.3	554	2.1	6.7		950		1.8	30
		66.7	219	3.1	13.3	518	2.0					30	25.0	710	1.5	5.0		1210		1.3	40
		50.0	288	2.2	10.0	662	1.5					40	20.0	876	1.2	4.0		1464		1.0	50
		40.0	347	1.7	8.0	780	1.2					50	16.7	1008	1.0	3.3		1642		0.9	60
33.3	405	1.3	6.7	893	0.9	60	CMV 130/15	12.5	1229	0.7	2.5	1958	0.6	80	CMV 130/40						
	25.0	504	0.9	5.0	1094	0.7			80	40.0	486	2.2	8.0	876		1.7	25				
	50.0	281	3.1	10.0	653	1.9			40	33.3	554	2.1	6.7	950		1.8	30				
	40.0	347	2.4	8.0	804	1.5			50	25.0	710	1.5	5.0	1210		1.3	40				
	33.3	405	1.9	6.7	922	1.2			60	20.0	876	1.2	4.0	1464		1.0	50				
	25.0	504	1.4	5.0	1114	0.9			80	16.7	1008	1.0	3.3	1642		0.9	60				
100LA4 n ₁ =1400 [min ⁻¹]	20.0	603	1.0	4.0	1272	0.7	100	112M4 n ₁ =1400 [min ⁻¹]	133	211	1.8	26.7	398	1.7	7.5	CMV 090/40					
	133	117	2.2	26.7	219	2.0	7.5		100	278	1.5	20.0	512	1.4	10						
	100	153	1.8	20.0	281	1.7	10		66.7	403	1.2	13.3	720	1.1	15						
	66.7	224	1.3	13.3	394	1.2	15		CMV 075/22	50.0	525	0.8	10.0	922	0.8	20	CMV 110/40				
		133	119	3.2	26.7	224	2.9				7.5	100	275	2.7	20.0	518		2.4	10		
		100	157	2.7	20.0	288	2.4				10	66.7	398	2.0	13.3	739		1.8	15		
		66.7	227	2.1	13.3	405	2.0				15	50.0	525	1.4	10.0	973		1.3	20		
		50.0	295	1.5	10.0	518	1.4				20	40.0	648	1.1	8.0	1184		1.0	25		
		40.0	360	1.1	8.0	621	1.1				25	33.3	720	1.2	6.7	1248		1.2	30		
	33.3	410	1.3	6.7	713	1.2	30		CMV 090/22	25.0	960	0.9	5.0	1664	0.8	40	CMV 130/40				
		133	119	5.7	26.7	224	5.1				7.5	40.0	648	1.6	8.0	1168		1.3	25		
		100	157	4.7	20.0	292	4.3				10	33.3	739	1.6	6.7	1267		1.3	30		
66.7		227	3.5	13.3	410	3.3	15	25.0			947	1.2	5.0	1613	1.0	40					
50.0		299	2.5	10.0	540	2.4	20	20.0			1168	0.9	4.0	1952	0.8	50					
40.0		369	1.9	8.0	648	1.9	25	16.7			1344	0.7	3.3	2189	0.6	60					
33.3	421	2.1	6.7	724	2.0	30	CMV 110/22	25.0	947	1.2	5.0	1613	1.0	40	CMV 130/40						
	25.0	540	1.5	5.0	936	1.4			40	20.0	1168	0.9	4.0	1952		0.8	50				
	20.0	639	1.2	4.0	1098	1.1			50	16.7	1344	0.7	3.3	2189		0.6	60				
	16.7	734	0.9	3.3	1231	0.8			60	33.3	739	1.6	6.7	1267		1.3	30				
	33.3	416	2.8	6.7	713	2.4			30	25.0	947	1.2	5.0	1613		1.0	40				
	25.0	533	2.1	5.0	907	1.8			40	20.0	1168	0.9	4.0	1952		0.8	50				
20.0	657	1.6	4.0	1098	1.4	50	CMV 130/22	16.7	756	1.3	3.3	1231	1.1	60	12.5	922	1.0	2.5	1469	0.8	80
	16.7	756	1.3	3.3	1231	1.1			60	12.5	922	1.0	2.5	1469		0.8	80				
	12.5	922	1.0	2.5	1469	0.8			80		12.5	922	1.0	2.5		1469	0.8	80			
	12.5	922	1.0	2.5	1469	0.8			80			12.5	922	1.0		2.5	1469	0.8	80		





Dimensioni

Dimensions

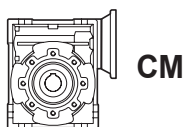

CM

CM.. - CM..F - CM..FB - CM..FL																									
	A	C	D _{H8}	E	F	G	G1	H	I	L	M	N _{h8}	N1	O	P	Q	R	S	T	V	K	KE	a	b	t
040	70	100	18 (19)	121.5	43	70	78	50	40	71	75	60	36.5	6.5	87	55	71.5	6.5	26	35	60	M6x8 (n.4)	45°	6	20.8 (21.8)
050	80	120	25 (24)	144	49	80	92	60	50	85	85	70	43.5	8.5	100	64	84	7	30	40	70	M8x10 (n.4)	45°	8	28.3 (27.3)
063	100	144	25	174	67	95	112	72	63	103	95	80	53	8.5	110	80	102	8	36	50	85	M8x10 (n.8)	45°	8	28.3
075	120	172	28	205	72	112.5	120	86	75	112	115	95	57	11	140	93	119	10	40	60	90	M8x14 (n.8)	45°	8	31.3
090	140	205	35	238	74	129.5	140	102.5	90	130	130	110	67	13	160	102	135	11	45	70	100	M10x18 (n.8)	45°	10	38.3
110	170	252.5	42	295	—	160	155	127.5	110	144	165	130	74	14	200	125	167.5	14	50	85	115	M10x18 (n.8)	45°	12	45.3
130	200	292.5	45	335	—	180	170	147.5	130	155	215	180	81	16	250	140	187.5	15	60	100	120	M12x21 (n.8)	45°	14	48.8

	CM..F									CM..FB						CM..FL								
	a1	KA	KB	KC	KM	KN _{H8}	KO	KP	KQ	KA	KB	KC	KM	KN _{H8}	KO	KP	KA	KB	KC	KM	KN _{H8}	KO	KP	KQ
040	45°	67	7.5	4	80-95	60	9(n.4)	110	95	80	8.5	5	115-125	95	9.5(n.4)	140	97	7.5	4.5	80-95	60	10(n.4)	110	95
050	45°	90	9	5	90-110	70	11(n.4)	125	110	89	9	5	130-145	110	9.5(n.4)	160	120	9	5	90-110	70	11(n.4)	125	110
063	45°	82	10	6	150-160	115	11(n.4)	180	142	98	10	5	165-180	130	11(n.4)	200	112	10	6	150-160	115	11(n.4)	180	142
075	45°	111	13	6	165-180	130	14(n.4)	200	170	—	—	—	—	—	—	—	—	—	—	—	—	—	—	—
090	45°	111	13	6	175-190	152	14(n.4)	210	200	—	—	—	—	—	—	—	—	—	—	—	—	—	—	—
110	45°	131	15	6	230	170	14(n.8)	280	260	—	—	—	—	—	—	—	—	—	—	—	—	—	—	—
130	45°	140	15	6	255	180	16(n.8)	320	290	—	—	—	—	—	—	—	—	—	—	—	—	—	—	—

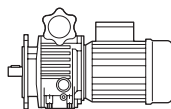

VAM

VAM								
	V2	V3	VC	VF	VL	VR	VR1	VS
018	112.5	64.5	71	111	78	110	110	85
037	110	74	71	123	90	110	110	85
075	139	85.5	79	140	107	120	120	85
15	188	115	—	144	122	120	120	85
22	208	131	—	188	150	160	—	110
40	208	131	—	188	150	160	—	110

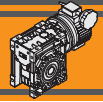

Dimensioni

Dimensions

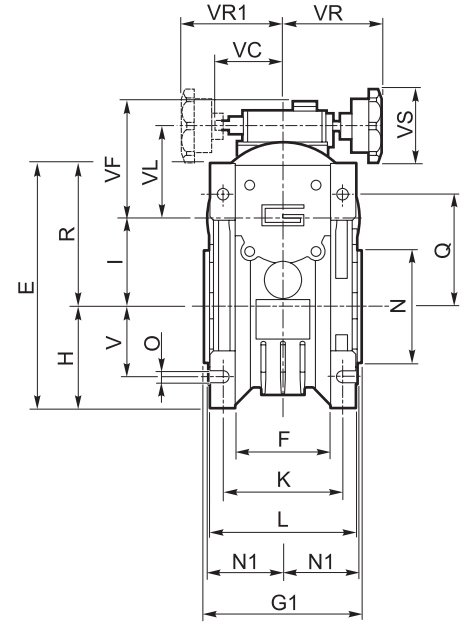
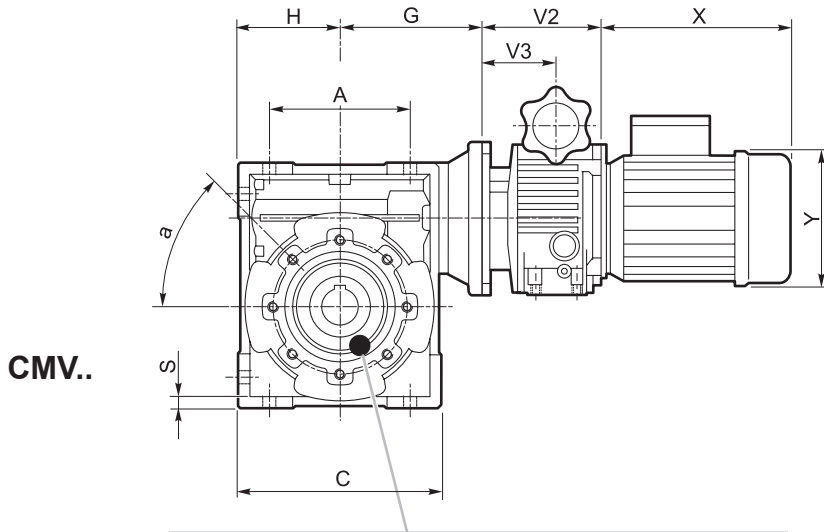

CMV..U

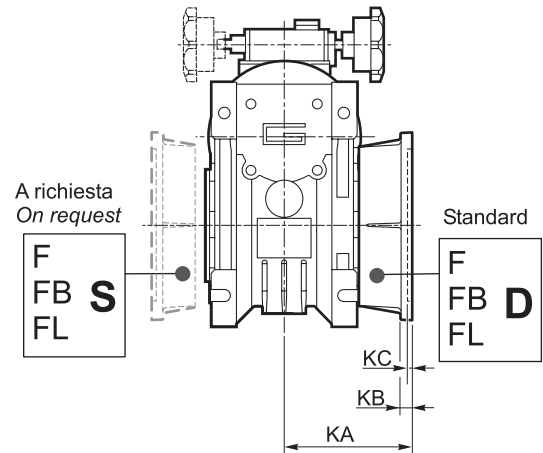
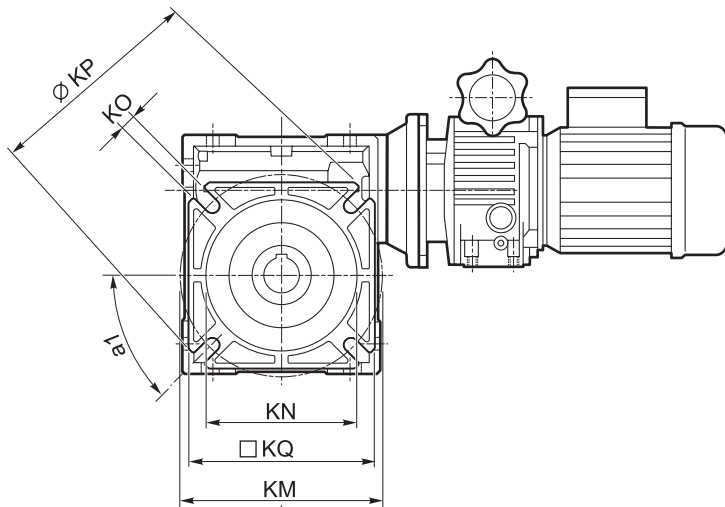
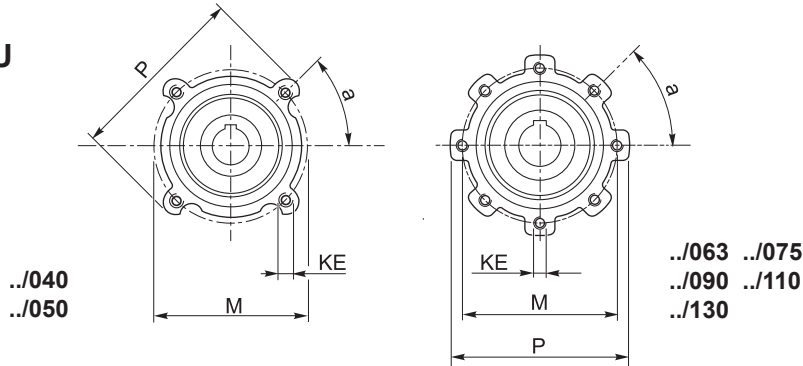

CMV..F (../040 - ../090)
CMV..FB (../040 - ../063)
CMV..FL (../040 - ../063)

CMV..F (../110, ../130)

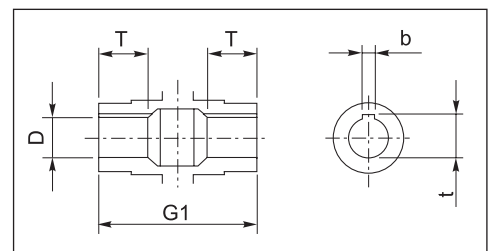
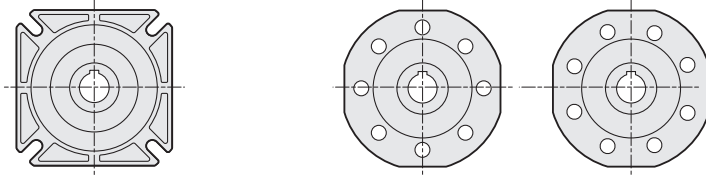

Albero lento cavo / Hollow output shaft



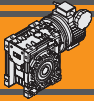

Accessori

Accessories

Albero lento semplice e doppio

Single and double output shaft

	d _{h7}	B	B1	G1	L	L1	f	b1	t1
CM 040	18	40	43	78	128	164	M6	6	20.5
CM 050	25	50	53.5	92	153	199	M10	8	28
CM 063	25	50	53.5	112	173	219	M10	8	28
CM 075	28	60	63.5	120	192	247	M10	8	31
CM 090	35	80	84.5	140	234	309	M12	10	38
CM 110	42	80	84.5	155	249	324	M16	12	45
CM 130	45	80	85	170	265	340	M16	14	48.5

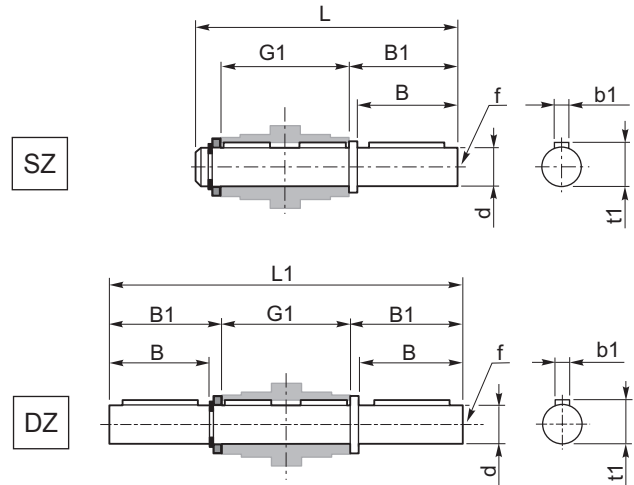

Braccio di reazione

Torque arm

	K1	G	KG	KH	R
CM 040	100	14	31	10	18
CM 050	100	14	38	10	18
CM 063	150	14	47.5	10	18
CM 075	200	25	46.5	20	30
CM 090	200	25	56.5	20	30
CM 110	250	30	62	25	35
CM 130	250	30	69	25	35

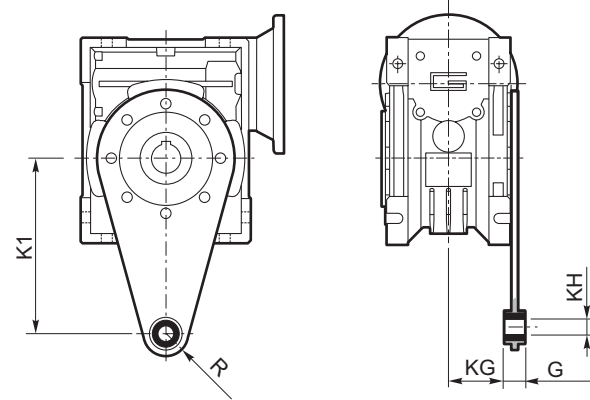

Opzioni

Options

VS - Vite sporgente / Extended input shaft

SC - Safety cover

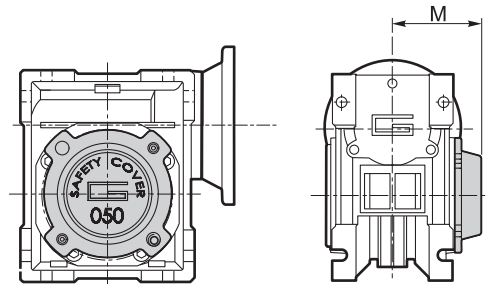
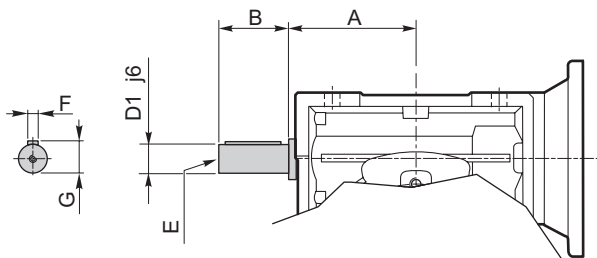

	A	B	D ₁ _{j6}	E	F	G
CM 040	53	23	11	M5	4	12.5
CM 050	64	30	14	M6	5	16
CM 063	75	40	19	M6	6	21.5
CM 075	90	50	24	M8	8	27
CM 090	108	50	24	M8	8	27
CM 110	—	—	—	—	—	—
CM 130	—	—	—	—	—	—

	M
CM 040	54.5
CM 050	62.5
CM 063	73
CM 075	79
CM 090	94
CM 110	102
CM 130	117